



POWERLIFT 2000 · 拓力 2000

75 t capacity · 75 t 起重能力

Crawler Crane

履带起重机

Datasheet metric

参数表 (公制)

POWERLIFT 2000

拓力 2000



WORKS FOR YOU.™

Key · 关键词汇	3
-------------------	---

Highlights · 技术亮点	4
--------------------------	---

Specifications · 技术参数	5
------------------------------	---

Specifications · 技术参数	5
-----------------------	---

Main boom configurations · 主臂的配置	7
----------------------------------	---

Boom combinations · 臂杆组合	9
--------------------------	---

Main boom · 主臂	10
-----------------------	----

Working ranges · 工作范围	10
-----------------------	----

Lifting capacities · 起重能力	11
---------------------------	----

Fixed jib · 固定副臂	12
-------------------------	----

Working ranges · 工作范围	12
-----------------------	----

Lifting capacities · 起重能力	13
---------------------------	----

Technical description · 技术描述	14
-------------------------------------	----

Transport example · 运输实例	16
---------------------------------	----



Counterweight · 配重



Track · 履带



Load radius · 载荷半径



Main boom · 主臂



Fixed jib · 固定副臂



Main boom angle · 主臂角度



Fixed jib angle · 固定副臂角度

“D”



H: Main boom · 主臂

F: Fixed jib · 固定副臂

HIGHLIGHTS · 技术亮点

POWERLIFT 2000
拓力 2000

- ▶ 75 t lifting capacity at 3.8 m radius
- ▶ Excellent lifting capacities throughout the whole working range
- ▶ Advantages with sole gantry structure for the same scale in its field, easy assembly and short rigging time
- ▶ Imported controller with colored display

- ▶ 3.8 m半径内的75吨履带起重机
- ▶ 任何工作范围都具有优异的起重性能
- ▶ 国内同级别唯一采用扳起架型式，组装极为简化，缩短装配时间
- ▶ 进口控制器配以彩色显示屏、监视器



SPECIFICATIONS · 技术参数

POWERLIFT 2000
拓力 2000

Working speeds · 工作速度

Mechanisms 机械部分	Rope \varnothing 钢绳 \varnothing	Speeds ¹⁾ 速度 ¹⁾	Single line pull ²⁾ 单绳拉力 ²⁾	Length of hoist rope 卷扬钢绳的长度
Hoist I (H1) 卷扬 I (H1)	20 mm	max. 120 m / min	67 kN / 57 kN	235 m
Hoist II (H2) 卷扬 II (H2)	20 mm	max. 120 m / min	63 kN / 59 kN	150 m
Boom derricking (W) 主臂变幅 (W)	22 mm	max. 41 m / min	72 kN / 68 kN	140 m
Slewing (rpm) 回转 (rpm)		1.7		

1) top layer · 顶层

2) without / with reeving effect considered · 不考虑 / 考虑穿绳效率

Basic crane dimensions · 起重机基本尺寸

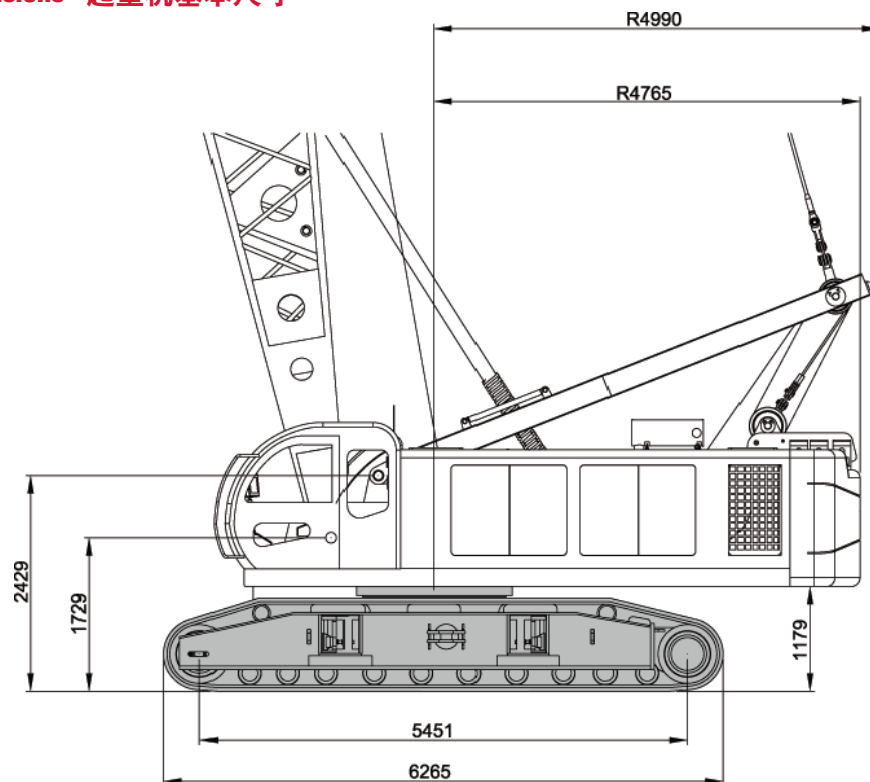

Carrier performance with standard drive · 带标准驱动的底盘性能

Travel speed on crawlers · 行走速度

0-1.4 km/h

Hook blocks · 吊钩

Type 类型	Possible load 可能的载荷	Number of sheaves 滑轮组数	Number of lines 绳数	Weight 重量	„D“
75	75 t	6	12	0.66 t	4.0 m
35	35 t	3	6	0.40 t	3.5 m
7	6 t	–	1	0.25 t	1.5 m

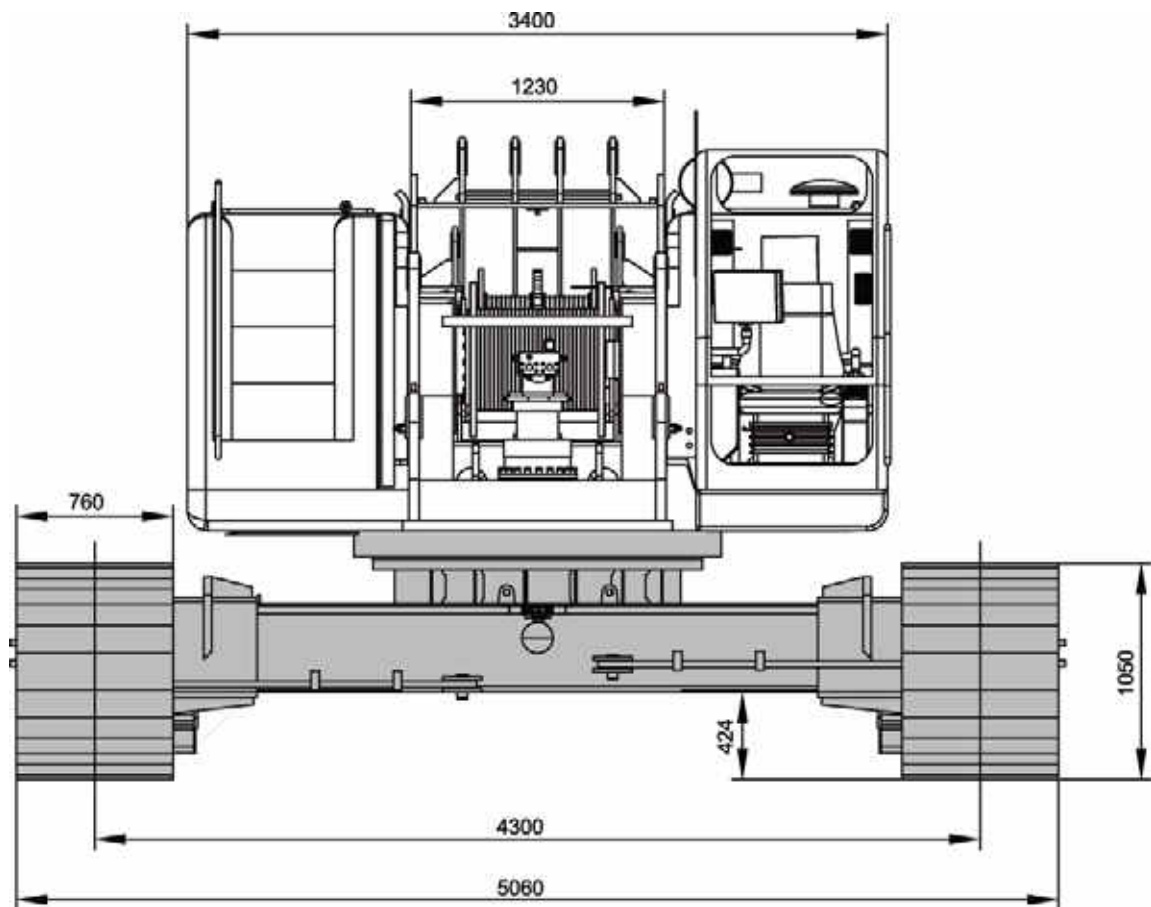

MAIN BOOM CONFIGURATIONS · 主臂的配置

POWERLIFT 2000
拓力 2000

Weights · 重量

Total weight incl. counterweight 21.6 t, 12 m H boom and hook block 总重量包括 21.6 吨的配重、12 m 的H起重臂和吊钩	66 t
Superstructure (with three drums, gantry, boom foot and boom backstops) 上车 (带有三个卷扬、扳起架、主臂根和主臂防后倾)	17.9 t
Car body 车体	7.8 t
Crawlers with standard drive 履带带有标准驱动器	17.3 t
Counterweight 配重	21.6 t

Ground pressure · 接地比压

Ground pressure, based on 66 t total weight 基于 66 吨总重时的接地比压	7.3 N/cm ²
--	-----------------------

MAIN BOOM CONFIGURATIONS · 主臂的配置

POWERLIFT 2000
拓力 2000

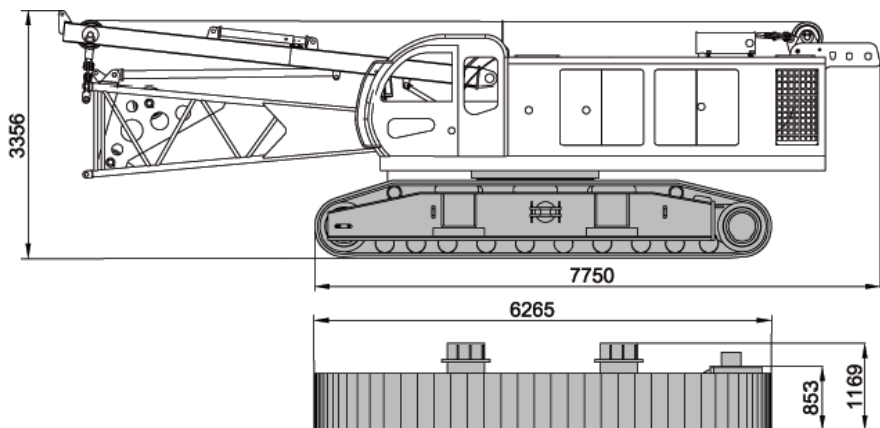

Counterweights on basic machine · 上车配重

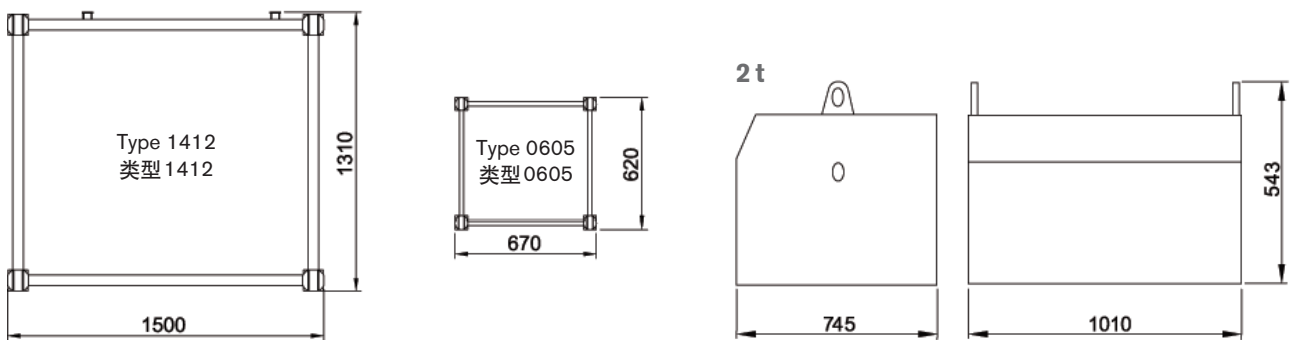
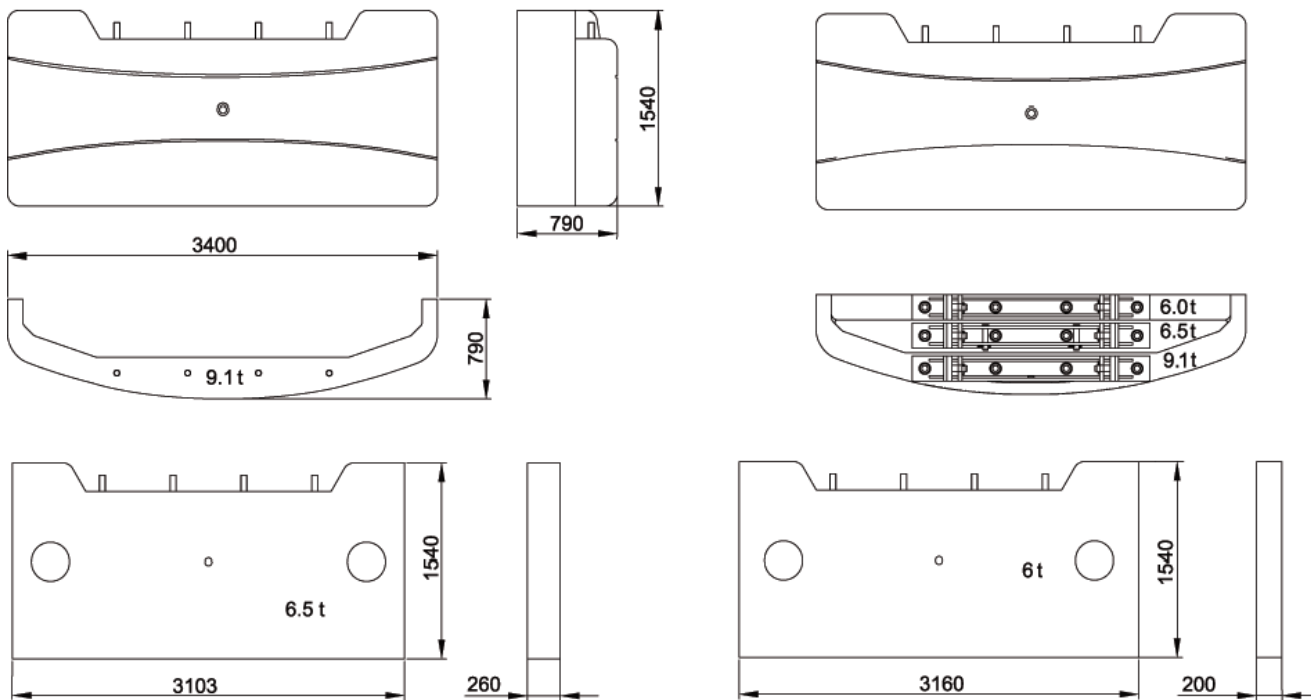

BOOM COMBINATIONS · 臂杆组合

POWERLIFT 2000
拓力 2000

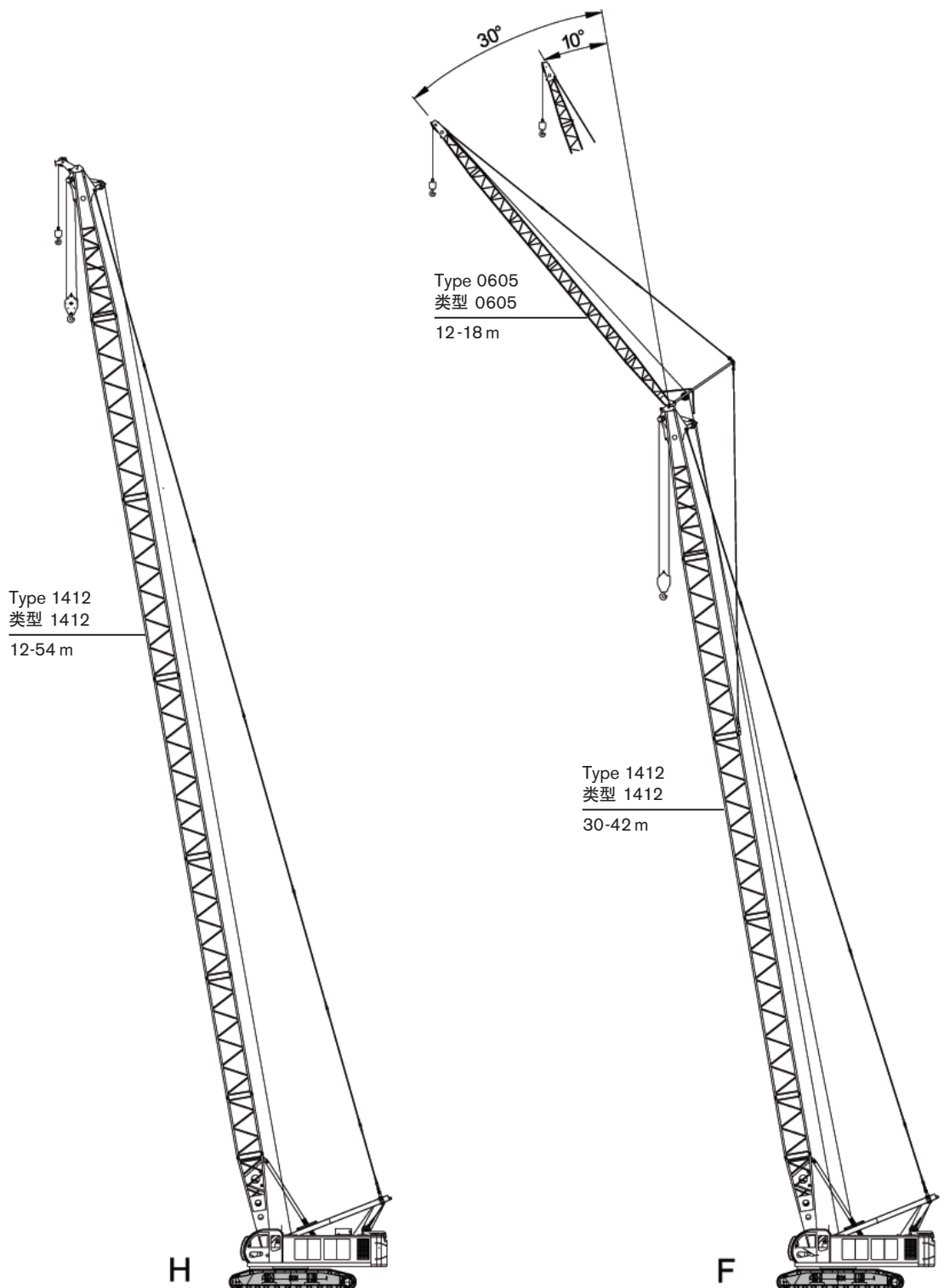

MAIN BOOM · 主臂

Working ranges · 工作范围

POWERLIFT 2000



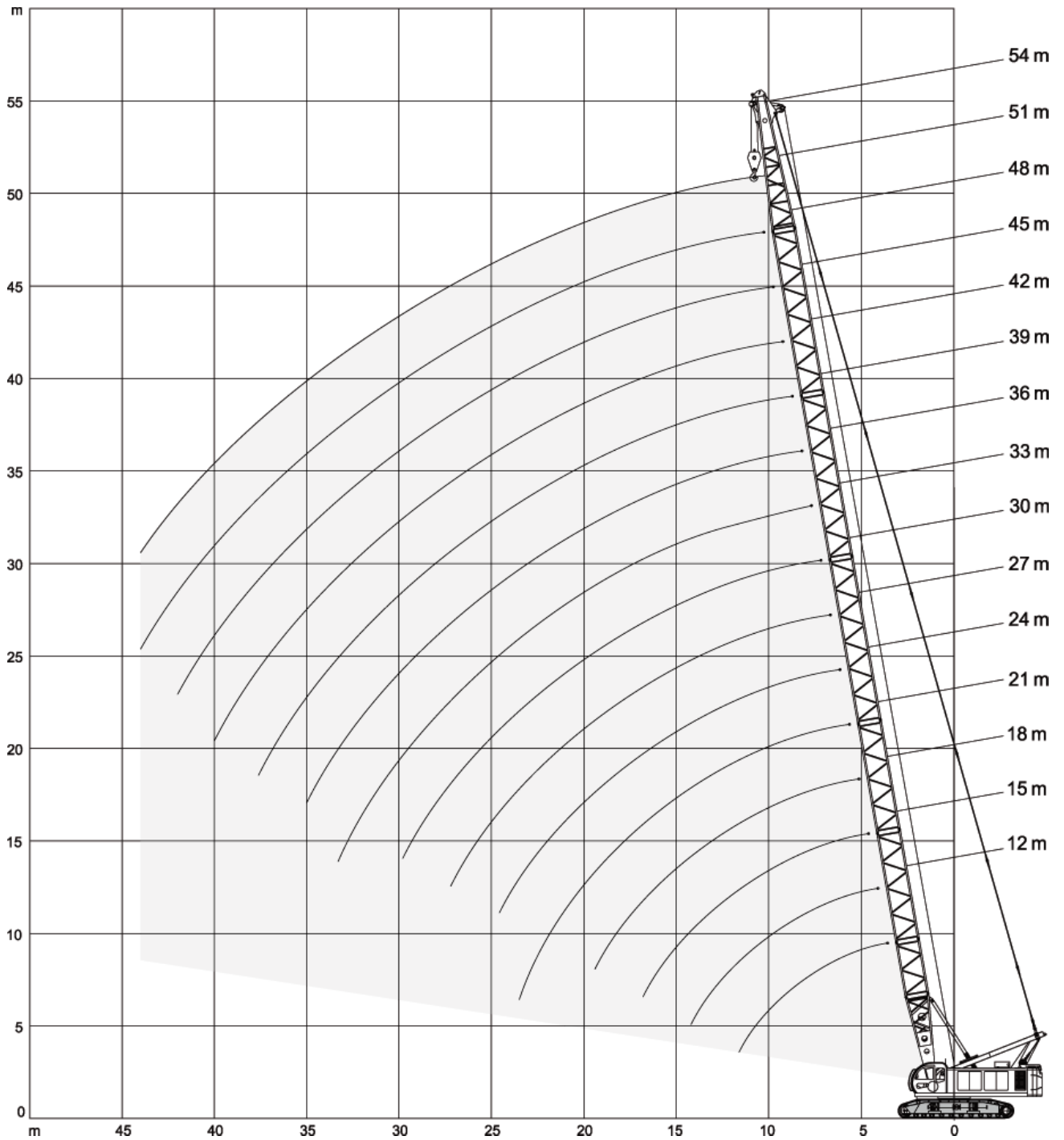

拓力 2000







MAIN BOOM · 主臂

Lifting capacities · 起重能力

POWERLIFT 2000
拓力 2000

21.6 t + 2 t		4.3 m		360°		GB / ISO				
										
12 m		15 m	18 m	21 m	24 m	27 m	30 m	33 m		
m	t	t	t	t	t	t	t	t	m	m
3.8	75.0	-	-	-	-	-	-	-	3.8	3.8
4.0	71.0	71.0	-	-	-	-	-	-	4.0	4.0
5.0	57.0	57.0	56.0	53.8	-	-	-	-	5.0	5.0
6.0	44.0	43.6	43.0	42.5	42.0	-	-	-	6.0	6.0
7.0	35.0	34.5	34.0	33.5	33.5	33.0	33.0	-	7.0	7.0
8.0	29.0	29.0	28.0	27.9	27.5	27.5	27.0	27.0	8.0	8.0
9.0	24.4	24.0	24.0	24.0	24.0	24.0	24.0	23.0	9.0	9.0
10.0	20.9	20.5	20.5	20.5	20.5	20.3	20.0	20.0	10.0	10.0
11.0	18.3	18.4	18.3	18.3	18.0	18.0	17.5	17.5	11.0	11.0
12.0	-	16.3	16.2	16.2	16.0	16.0	16.0	16.0	12.0	12.0
13.0	-	14.5	14.5	14.5	14.5	14.4	14.4	14.0	13.0	13.0
14.0	-	13.1	13.1	13.1	13.0	12.9	12.9	12.9	14.0	14.0
15.0	-	-	11.9	11.9	11.8	11.7	11.6	11.5	15.0	15.0
16.0	-	-	10.9	10.8	10.8	10.7	10.7	10.6	16.0	16.0
18.0	-	-	-	9.2	9.1	9.0	9.0	9.0	18.0	18.0
20.0	-	-	-	-	7.8	7.8	7.8	7.8	20.0	20.0
22.0	-	-	-	-	6.8	6.7	6.7	7.0	22.0	22.0
24.0	-	-	-	-	-	6.1	6.1	6.1	24.0	24.0
26.0	-	-	-	-	-	-	5.4	5.3	26.0	26.0
28.0	-	-	-	-	-	-	-	4.7	28.0	28.0

									
36 m		39 m	42 m	45 m	48 m	51 m	54 m		
m	t	t	t	t	t	t	t	m	m
8	26.7	-	-	-	-	-	-	8	8
9	23.0	23.0	22.5	-	-	-	-	9	9
10	20.0	20.0	19.5	19.2	17.5	-	-	10	10
11	17.5	17.2	17.0	16.8	16.5	15.5	14.5	11	11
12	16.0	15.8	15.5	15.0	14.8	14.6	13.7	12	12
13	14.0	13.8	13.8	13.5	13.2	13.2	13.1	13	13
14	12.5	12.3	12.2	12.0	11.9	11.8	11.0	14	14
15	11.4	11.4	11.3	11.0	10.8	10.6	9.6	15	15
16	10.5	10.4	10.3	10.0	9.8	9.7	9.5	16	16
18	9.0	8.9	8.7	8.5	8.4	8.2	8.0	18	18
20	7.8	7.8	7.7	7.6	7.5	7.4	7.2	20	20
22	6.9	6.8	6.7	6.6	6.4	6.3	6.2	22	22
24	6.0	5.9	5.8	5.7	5.6	5.5	5.2	24	24
26	5.2	5.2	5.0	4.9	4.8	4.7	4.6	26	26
28	4.6	4.5	4.4	4.3	4.2	4.1	4.0	28	28
30	4.1	4.0	3.9	3.8	3.7	3.6	3.5	30	30
32	3.6	3.5	3.4	3.3	3.2	3.1	3.0	32	32
34	-	3.1	3.0	2.9	2.8	2.7	2.6	34	34
36	-	-	2.7	2.6	2.5	2.4	2.2	36	36
38	-	-	-	2.3	2.1	2.0	1.9	38	38
40	-	-	-	2.0	1.9	1.8	1.6	40	40
42	-	-	-	-	1.6	1.5	1.4	42	42

In case of 30-54 m main boom configuration, 2 t additional counterweights needed

主臂工况为30-54m时, 需采用2t 附加配重

FIXED JIB · 固定副臂

Working ranges · 工作范围

POWERLIFT 2000
拓力 2000

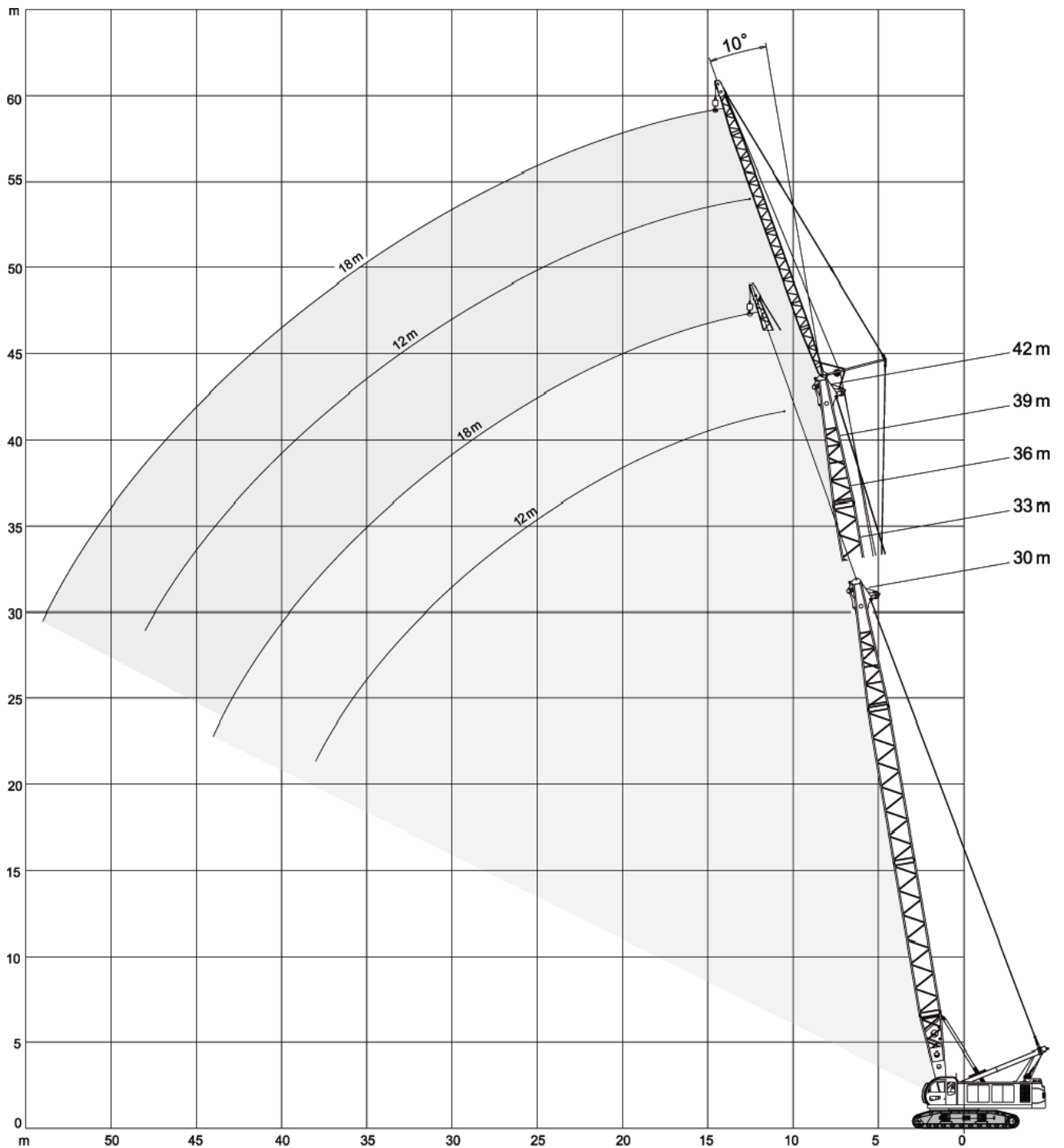

FIXED JIB · 固定副臂

Lifting capacities · 起重能力

POWERLIFT 2000
拓力 2000

21.6 t		12 m		4.3 m		360°		GB / ISO			
m	30 m		33 m		36 m		39 m		42 m		m
	10°	30°	10°	30°	10°	30°	10°	30°	10°	30°	
8.0	-	-	-	-	-	-	-	-	-	-	8.0
10.0	-	-	-	-	-	-	6.0	-	-	-	10.0
12.0	5.9	-	6.0	-	6.0	-	5.9	-	-	-	12.0
14.0	5.7	4.8	5.8	-	5.8	-	5.7	-	5.9	-	14.0
16.0	5.5	4.7	5.6	4.7	5.7	4.8	5.6	4.8	5.7	4.8	16.0
18.0	5.4	4.6	5.4	4.6	5.5	4.7	5.4	4.7	5.6	4.7	18.0
20.0	5.2	4.5	5.3	4.6	5.4	4.6	5.3	4.6	5.5	4.6	20.0
22.0	5.1	4.4	5.2	4.6	5.2	4.5	5.2	4.5	5.4	4.6	22.0
24.0	5.0	4.4	5.1	4.5	5.1	4.4	5.0	4.5	4.9	4.4	24.0
26.0	4.8	4.3	4.7	4.4	4.6	4.4	4.4	4.4	4.3	4.1	26.0
28.0	4.3	4.2	4.1	4.2	4.0	4.1	3.9	4.0	3.8	3.7	28.0
30.0	3.8	3.8	3.6	3.7	3.5	3.6	3.4	3.5	3.3	3.2	30.0
32.0	3.4	3.4	3.2	3.3	3.1	3.2	3.1	3.1	3.0	2.9	32.0
34.0	3.1	3.1	3.0	3.0	2.8	2.9	2.7	2.8	2.6	2.6	34.0
36.0	2.8	2.8	2.7	2.7	2.5	2.6	2.4	2.4	2.3	2.3	36.0
38.0	2.4	2.4	2.3	2.3	2.2	2.2	2.1	2.1	2.0	2.0	38.0
40.0	-	-	2.1	2.1	2.0	2.0	1.9	1.9	1.7	1.8	40.0
42.0	-	-	1.8	1.8	1.8	1.8	1.6	1.6	1.5	1.5	42.0
44.0	-	-	-	-	1.5	1.5	1.5	1.5	1.4	1.4	44.0
46.0	-	-	-	-	-	-	1.3	1.3	1.2	1.2	46.0
48.0	-	-	-	-	-	-	-	-	1.0	1.0	48.0

21.6 t		18 m		4.3 m		360°		GB / ISO			
m	30 m		33 m		36 m		39 m		42 m		m
	10°	30°	10°	30°	10°	30°	10°	30°	10°	30°	
12.0	-	-	-	-	-	-	-	-	-	-	12.0
14.0	5.1	-	5.1	-	5.2	-	5.2	-	-	-	14.0
16.0	4.9	-	4.9	-	5.0	-	4.5	-	5.1	-	16.0
18.0	4.7	3.9	4.8	-	4.8	-	4.5	-	4.5	-	18.0
20.0	4.5	3.8	4.6	3.8	4.4	3.8	4.4	3.8	4.4	3.8	20.0
22.0	4.3	3.6	4.3	3.6	4.2	3.6	4.3	3.7	4.4	3.7	22.0
24.0	4.0	3.4	4.1	3.4	4.2	3.5	4.3	3.5	4.3	3.5	24.0
26.0	3.8	3.3	3.9	3.3	4.2	3.4	4.2	3.4	4.3	3.4	26.0
28.0	3.6	3.1	3.7	3.2	4.0	3.2	3.9	3.2	3.9	3.3	28.0
30.0	3.5	3.0	3.5	3.1	3.6	3.1	3.5	3.1	3.4	3.1	30.0
32.0	3.3	3.0	3.3	3.0	3.2	3.0	3.1	3.0	3.1	3.0	32.0
34.0	3.1	2.8	3.1	2.9	2.9	2.9	2.8	2.9	2.7	2.9	34.0
36.0	2.9	2.7	2.7	2.8	2.6	2.7	2.5	2.6	2.4	2.5	36.0
38.0	2.6	2.6	2.4	2.5	2.3	2.4	2.2	2.3	2.1	2.2	38.0
40.0	2.3	2.3	2.2	2.2	2.1	2.1	1.9	2.0	1.8	1.9	40.0
42.0	2.1	2.1	2.0	2.0	1.8	1.9	1.7	1.8	1.6	1.7	42.0
44.0	1.8	1.8	1.7	1.7	1.6	1.6	1.5	1.6	1.5	1.5	44.0
46.0	-	-	-	-	1.5	1.5	1.4	1.4	1.3	1.3	46.0
48.0	-	-	-	-	1.3	1.3	1.2	1.2	1.1	1.1	48.0
50.0	-	-	-	-	1.1	1.1	1.1	1.1	1.0	1.0	50.0
52.0	-	-	-	-	-	-	0.9	0.9	0.8	0.8	52.0
54.0	-	-	-	-	-	-	-	-	0.7	0.7	54.0

Crawler Carrier

	3-section carrier comprising of carbody and two crawlers. Hydraulic cylinder connections between crawlers and carbody provide for easy assembly and removal to minimise width for transportation.
Carbody	Bending- and torsion-resistant welded structure of box type construction, fabricated of structural steel.
Crawlers	Side frames: bending-resistant welded structure of structural steel. Track shoes, idler and drive sprockets are fabricated of heat treated high-strength cast steel. 10 rollers on each side frame with hardened rolling surfaces.
Power train	Inclined-shaft piston fixed displacement/variable motor is desinged; and the plug-in double way brake valve is installed face to face, and the brake relief valve is arranged, which shall automatically switch brake according to various main oil pressure, simplifying operation procedure. Built-in motor almost fully embedded inside of reducer, minimizing structure size. Hydraulic motor at each side operates driven wheel by planetary reducer to drive crawler. Each crawler can be both independently and in opposite direction.

Superstructure

Counterweight	21.6 t, additional counterweight 2 t.
Frame	Torsion-resistant welded structure fabricated of structural steel.
Drive	WEICHAI DEUTZ WP6L.240, in-line with six-cylinder engine, 176 kW (240 hp) at 2300 rpm. The engine complies with GB 3 regulation.
Rope drums	The standard superstructure equipment includes three rope drums – hoist 1, hoist 2 and boom hoist. The drums are powered by hydraulic motors through planetary gear reducer, internal-mounted normal-closed wet disc brake. LEBUS drum is adopted to ensure reeving in multiple layers. Luffing drum is designed with ratchet locking device.
Gantry	Gantry is included as standard.
Slew unit	Pinion of slewing reducer internally engaged with slewing bearing, and the pinion is driven with slewing motor by planetary gear reducer, normal-closed disc brake with buffer braking oil circuit shall enable more stable slewing brake. The designed slewing inertia valve may function accurate slewing, which may realize the function of alignment load's center of gravity.
Control system	Equipped with imported controller with color LCD for easily control and monitoring. Controller receives information from control handle and dominates action of the crane. Information about engine parameter, hydraulic system, and load moment can be showed on the display, and the screen also displays the relevant fault code when the system works in abnormal condition. CAN BUS communication system transfers the data among the electrical equipments. Designed with limit load adjustment controller which can regulate hydraulic system according to load in order to prevent engine stalling. The crane is controlled by imported hydraulic pilot joystick. All the working speeds are variable controlled by the lever position, enabling smooth and easy operating. Provided with guard switch to prevent misoperation.
Cabin	The cabin is fully closed with large windscreen and designed with front light, rear view mirror, air conditioner, heater, stereo and adjusted seat. The colorful touched display and monitor make operation more convenient.
Electrical equipment	24 V DC system (2 × storage batteries 12 V, 165 Ah).

Boom configurations

H:	Main boom: foot section 5 m Insert: 3 m, 6 m and 9 m Main boom lengths: 12-54 m.
F:	Main boom: same as H. Main boom lengths: 30-42 m Fixed jib lengths: 12 m, 18 m Fixed jib offset: 10°, 30°.
Operator aids	Load moment indicator, independent LCD monitor, boom limit switch, height limit switch, anemoscope and gradient indicator.

底盘

底盘	底盘由三部分组成，车体和两个履带。车体和履带间由液压油缸连接，以减少运输宽度。
车身	箱型结构抗弯、抗扭，由结构钢焊接制造。
履带	履带架：由抗弯结构钢焊接制成。履带板、从动轮和驱动轮均由高强度热处理铸钢制造。在每边有10个经表面硬化处理过的支重轮。
传动系	斜轴式柱塞定量/变量马达。贴面安装插装式双向制动阀，并带有制动释放阀。制动器释放阀可以根据主油路压力自动打开制动器，简化操作步骤。内藏式马达使自身几乎全部插入减速机中，大大减小了结构尺寸。每侧的液压马达通过行星减速机带动驱动轮来驱动两侧的履带。每条履带既可独立，也可反向行走。

上车

配重	21.6 t 配重, 附加配重 2t。
机台	由抗扭结构钢焊接制成。
驱动	潍柴道依茨直列六缸式发动机，型号WP6L240，功率176 kW (240 hp)，转速2300 rpm。发动机符合国3标准。
钢绳卷扬	上车设备包括三个钢绳卷扬：起升 1，起升 2 和起重臂的起升。该卷扬由液压马达通过行星减速机驱动，内藏湿式常闭盘式制动器。采用LEBUS卷筒，保证多层缠绕不乱绳。变幅卷筒带有棘轮锁定装置。
扳起架	标准车型在上车配备扳起架。
回转装置	回转减速机小齿轮与回转轴承为内啮合，小齿轮有回转马达通过行星减速机驱动，常闭盘式制动器。具有缓冲制动油路，使回转制动更平稳。带有回转惯性阀，可精确回转，可实现自动正钩的功能。
控制系统	采用进口控制器配以彩色液晶显示器控制，便于控制及监视。控制器接受操作手柄控制信息并对吊车的动作进行控制，显示器显示发动机运行信息，液压系统信息，力矩信息以及吊车工作异常时相应的报警图标等。显示器所有电器设备之间通过CAN总线进行通讯。设置有极限负载调节功能，根据发动机负载情况调节液压系统，防止发动机憋车。进口液控先导手柄，所有工作速度均可以通过控制拉杆位置进行变速控制，操作平稳方便，具有保安开关，可以避免碰撞引起的误操作。
驾驶室	全封闭式驾驶室，冷暖风空调、立体声音响、全方位调整的座椅使操作更舒适，大面积玻璃窗、前照灯、后视镜，使视野更开阔。彩色液晶显示屏、监视器使监控更加方便安全。
电气设备	24 V d.c. 系统 (2 个蓄电池, 12 V, 165 Ah)。

臂杆组合





H:	主臂： 标准节： 主臂长度：	根部 5 m 3 m, 6 m 和 9 m 12-54 m。
F:	主臂： 主臂长度： 副臂长度： 副臂偏移：	与 H 相同。 30-42 m 12 m, 18 m 10°, 30°。
操作员辅助设备	力矩限制器、独立彩色监视器、臂架角度及吊钩高度限制开关，风速计和水平仪。	

TRANSPORT EXAMPLE · 运输实例

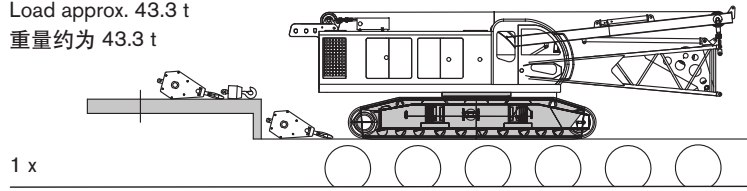
POWERLIFT 2000
拓力 2000

Load approx. 43.3 t
重量约为 43.3 t



-  Counterweight · 配重
-  Basic machine · 主机
-  Boom combination · 臂杆
-  Boom combination · 臂杆
-  Low loader · 低架拖车

Load 1.5 t
重量 1.5 t

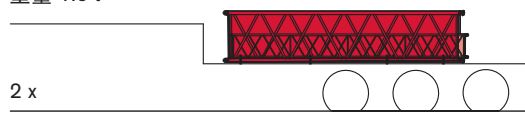

Load 2.5 t
重量 2.5 t

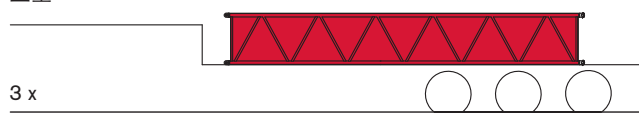

Load 2.0 t
重量 2.0 t

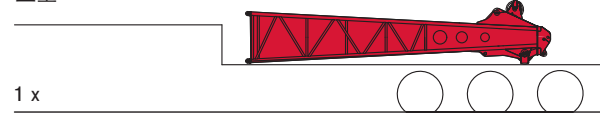

Load 23.9 t
重量 23.9 t

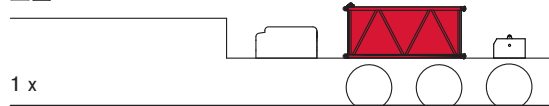

Load 0.3 t
重量 0.3 t

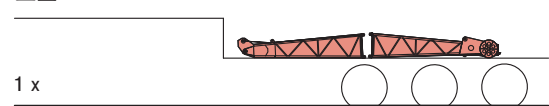

NOTES TO LIFTING CAPACITY · 起重能力注释

POWERLIFT 2000
拓力 2000

Ratings are in compliance with ISO 4305 and GB3811 (test load = 1.25 × suspended load).
Weight of hook blocks and slings is part of the load, and is to be deducted from the capacity ratings.
Consult operation manual for further details.

Note: Data published herein is intended as a guide only and shall not be construed to warrant applicability for lifting purposes.
Crane operation is subject to the computer charts and operation manual both supplied with the crane.

额定起重能力符合 ISO 4305 和 GB3811 (测试载荷 = 1.25 × 悬挂载荷)。
吊钩和吊具的重量是载荷的一部分，应从额定起重能力中扣除。

具体细节请参阅操作手册。

备注：在此所印数据仅供参考，不完全适用实际吊装操作。

实际起重机操作应根据与起重车辆同时提供的起重机载荷表及操作手册进行。

NOTES · 说明

The information contained in this brochure / product catalogue merely consists of general descriptions and a broad compilation of performance features which might not apply precisely as described under specific application conditions or which may change as a result of further product development.

The desired performance features only become binding once expressly agreed in the final contract.

Subject to change with out notice!

本手册/产品目录包含的资料只是一般性的说明和性能特点的广泛描述，可能与特定的使用条件不能准确匹配；
今后产品的开发也可能会对此进行一些修改。
一旦在最终合同中明确达成一致，所需的性能特点将具有约束力。

如有修改，恕不通知！

Effective Date: September 2012. Product specifications and prices are subject to change without notice or obligation. The photographs and/or drawings in this document are for illustrative purposes only. Refer to the appropriate Operator's Manual for instructions on the proper use of this equipment. Failure to follow the appropriate Operator's Manual when using our equipment or to otherwise act irresponsibly may result in serious injury or death. The only warranty applicable to our equipment is the standard written warranty applicable to the particular product and sale and Terex makes no other warranty, express or implied. Products and services listed may be trademarks, service marks or trade-names of Terex Corporation and/or its subsidiaries in the USA and other countries. All rights are reserved. Terex® is a registered trademark of Terex Corporation in the USA and many other countries. Copyright 2012 Terex Corporation.

生效日期：2012年9月。产品技术参数和价格如有更改，恕不另行通知。本文档中的图片和/或图纸仅作举例用途。有关正确使用本设备的说明，请参阅合适的操作手册。如果在使用本设备时，未按照操作手册正确操作，可导致严重的人身伤害或死亡。适用于我们设备的唯一保证是适用于特别产品和销售的标准书写保证，特雷克斯不做任何其他保证、表示或暗示。以上所列产品和服务为特雷克斯公司和/或其子公司在美国和其他国家/地区的商标、服务标记或厂商名称。保留所有版权。Terex®为特雷克斯公司在美国和许多其他国家的注册商标。©2012，特雷克斯公司版权所有。

Terex (China) Investment Co., Ltd

8th Floor, Tower B, GATEWAY, No 18 Xiaguangli, North Road, East 3rd Ring, Chaoyang District, Beijing, 100027 China
Phone: +86 10 5907 9000, Fax: +86 10 8440 0628, Email: cranes@terex.com, Web: www.terexcranes.com

特雷克斯（中国）投资有限公司

中国，北京市朝阳区东三环北路霞光里18号佳程广场B座8层，邮编100027
电话：+86 10 5907 9000，传真：+86 10 8440 0628，邮箱：cranes@terex.com，网址：www.terexcranes.com

Terex Topower (Shandong) Heavy Machinery Manufacture Co., Ltd.

Topower Industrial Park, Ming Shui Economic Development Area, Zhangqiu City, Shandong Province
Phone: +86 531 8372 5000, 8372 5016

特雷克斯拓能（山东）重机制造有限公司

山东省章丘市明水经济开发区拓能工业园，电话：+86 531 8372 5000, 8372 5016



www.terexcranes.com

Brochure Reference: TC-DS-M-E/C-POWERLIFT 2000 - 09.12
手册参考: TC-DS-M-E/C-拓力2000 - 09.12



WORKS FOR YOU.™